

**POWER PLANT (PT6A-140) - MAINTENANCE PRACTICES****1. General**

- A. Powerplant maintenance practices include engine removal, installation, configuring engine to ship for service, and engine build-up. For more data applicable to the removal and installation of the Pratt and Whitney PT6A-140 engine and engine components refer to the Pratt and Whitney PT6A-140 Maintenance Manual P/N 3075742 found in the Introduction List of Publications.

**2. Engine Removal/Installation**

- A. Remove Engine (Refer to Figure 201 and Figure 202).

**CAUTION: Chock the main wheels and place a tailstand under the tailcone when you do the engine removal.**

- (1) Remove external electrical power from the airplane.
- (2) Pull the fuel firewall shutoff control out (off).
- (3) Remove the cowling components as follows. Refer to Chapter 71, Engine Cowling and Nose Cap - Maintenance Practices:
  - (a) The upper cowling doors.
  - (b) The lower cowling panels.
  - (c) The right nose cap.
- (4) Use the filter drain to drain the residual fuel from lines and fuel filter. Refer to Chapter 28, Fuel Lines, Valves and Filters - Maintenance Practices.
- (5) Remove the fuel supply hose at the fuel heater. Refer to Chapter 73, Oil-To-Fuel Heater - Maintenance Practice section of the Pratt and Whitney PT6A-140 Maintenance Manual P/N 3075742 found in the Introduction List of Publications.
- (6) Remove the fuel motive flow hose at the motive flow shut-off valve. Refer to Chapter 73, Fuel Control Unit - Maintenance Practices section of the Pratt and Whitney PT6A-140 Maintenance Manual P/N 3075742 found in the Introduction List of Publications.
- (7) Remove the oil cooler. Refer to Chapter 79, Oil Distribution - Maintenance Practices (PT6A-140).
- (8) Remove top cowl center panel assembly and nose cap. Refer to Chapter 71, Engine Cowling and Nose Cap - Maintenance Practices
- (9) Remove the propeller. Refer to Chapter 61, Propeller (Hartzell) - Maintenance Practices.
- (10) Disconnect and remove propeller speed control cable. Refer to Chapter 76, Quadrant Assembly And Controls - Maintenance Practices.
- (11) Remove the left nose cap/induction air duct/inertial air separator. Refer to Chapter 71, Inertial Air Separator - Maintenance Practices.
- (12) Disconnect the cabin heater bleed air line at the flow control valve. Chapter 21, Compressor Bleed Air Heater - Maintenance Practices.
- (13) Disconnect the bleed air hose at mixing air valve. Chapter 21, Compressor Bleed Air Heater - Maintenance Practices
- (14) Remove the starter/generator cooling air hose from starter/generator. For the 300 Amp Starter/Generator refer to Chapter 80, 300 AMP Starter/Generator Cooling Air Duct - Maintenance Practices. For the 200 Amp Starter/Generator refer to Chapter 80, Starter/Generator Cooling Air Blast Tube - Maintenance Practices.
- (15) Remove the oil pressure switch supply hose. Refer to Chapter 79, Oil Pressure Switch - Maintenance Practices
- (16) Remove engine fire detector wiring harness. Chapter 26, Fire Detection System - Maintenance Practices.
- (17) Disconnect electrical wiring connectors and ground wires at the following equipment locations:
  - Battery Connector (PN004) (aft right side of engine)
  - Prop Overspeed Valve Connector (PN041) (left front of engine)
  - NP Speed Tach (PN033) (right front of engine)
  - Cabin Heat Bleed Air Valve connector (PN043) (lower right side of engine)
  - Oil Pressure Switch (PN030) (right side on engine truss).
  - Oil Temperature Sensor connector (PN031) (right rear of engine)
  - NG Speed Tach (PN034) rear, (lower right side of engine)

- Starter Generator Connector (PN002) (center top of engine accessory case)
- Ignition Exciter Connector (PN040) (right engine mount truss)
- Fuel Flow Connector (PN032) (rear, lower right side of engine)
- Torque Transducer (PN038) (right engine mount truss)
- RGB Chip Detector (PN035) (right engine mount truss)
- Engine ground straps airplane frame connections.

- (18) Disconnect the engine power control cables at fuel control unit. Refer to Chapter 73, Fuel Control Unit - Maintenance Practices section of the Pratt and Whitney PT6A-140 Maintenance Manual P/N 3075742 found in the Introduction List of Publications.
- (19) Remove torque meter pressure and vent lines at forward upper right side of engine mount truss. Refer to Chapter 77, Wet Torque Indicating System - Maintenance Practices (PT6A-140).
- (20) Connect hoist sling to forward and aft lifting brackets and connect sling to engine hoist.
- (21) Raise hoist to just support weight of engine and remove nuts and bolts at each of four corners of engine mounting ring.
- (22) Make sure that all wiring and lines are free, then carefully move hoist and engine forward to clear engine mount truss.
- (23) If engine is to be returned for overhaul or replaced refer to Prepare Engine to Send for Service.

B. Install Engine (Refer to Figure 201 and Figure 202).

- (1) If the engine is new or was at manufacturer for service, install engine components. Refer to Engine Build-Up.
- (2) Install the engine mount brackets, elastomers, and the engine mount ring.
- (3) Connect the lifting hoist sling to forward and aft lifting brackets on engine and lift engine in its correct position forward of engine mount.
- (4) Make sure that all engine lines and equipment are clear.
- (5) Put lubrication on the engine mount bolts before you install them to prevent corrosion.
- (6) Move the hoist and engine aft to align the engine mount ring holes with the holes in the engine mount.
- (7) Install the mount bolts and torque the bolt/nuts to 480 to 690 inch-pounds.
  - (a) Remove the hoist and sling
- (8) Connect torquemeter pressure and vent lines at upper left firewall.
  - (a) Do a leak test of the torquemeter pressure and vent lines. Refer to Chapter 77, Wet Torque indicating System - Maintenance Practices
- (9) Connect engine power controls at fuel control unit.
  - (a) Rig the fuel controls. Refer to Chapter 76, PT6A-140 Engine Power Control Rigging - Adjustment/Test.
- (10) Connect the electrical wiring connectors and ground wires at the following equipment locations:
  - Battery Connector (PN004) (aft right side of engine)
  - Prop Overspeed Valve Connector (PN041) (left front of engine)
  - NP Speed Tach (PN033) (right front of engine)
  - Cabin Heat Bleed Air Valve connector (PN043) (lower right side of engine)
  - Oil Pressure Switch (PN030) (right side on engine truss).
  - Oil Temperature Sensor connector (PN031) (right rear of engine)
  - NG Speed Tach (PN034) rear, (lower right side of engine)
  - Starter Generator connector (PN002) (center top of engine accessory case)
  - Ignition Exciter Connector (PN040) (right engine mount truss)
  - Fuel Flow connector (PN032) (rear, lower right side of engine)
  - Torque Transducer (PN038) (right engine mount truss)
  - RGB Chip Detector (PN035) (right engine mount truss)
  - Engine groundstraps airplane frame connections.
- (11) Install the oil pressure switch supply hose. Refer to Chapter 79, Oil Pressure Switch - Maintenance Practices
- (12) Install the engine fire detector wiring harness. Chapter 26, Fire Detection System - Maintenance Practices
- (13) Install the starter/generator cooling air hose to the starter/generator. For the 300 Amp Starter/Generator refer to Chapter 80, 300 AMP Starter/Generator Cooling Air Duct - Maintenance Practices. For the 200 Amp

Starter/Generator refer to Chapter 80, Starter/Generator Cooling Air Blast Tube - Maintenance Practices.

- (14) Connect the cabin heater bleed air line at the flow control valve. Chapter 21, Compressor Bleed Air Heater - Maintenance Practices.
- (15) Connect the bleed air hose at mixing air valve. Chapter 21, Compressor Bleed Air Heater - Maintenance Practices
- (16) If necessary, install the left nose cap/induction air duct/inertial air separator. Refer to Chapter 71, Inertial Air Separator - Maintenance Practices.
- (17) If necessary, install the propeller. Refer to Chapter 61, Propeller (Hartzell) - Maintenance Practices.
- (18) Install the propeller speed control cable. Refer to Chapter 76, Quadrant Assembly And Controls - Maintenance Practices.
- (19) Install left and right nose cap bulkhead assemblies and top cowling center panel. Refer to Chapter 71, Engine Cowling and Nose Cap - Maintenance Practices.
- (20) Install the oil cooler. Refer to Chapter 79, Oil Distribution - Maintenance Practices (PT6A-140).
- (21) Install the right nose cap. Refer to Chapter 71, Engine Cowling and Nose Cap - Maintenance Practices.
- (22) Install the fuel supply hose at the fuel heater. Refer to Chapter 73, Oil-To-Fuel Heater Unit - Maintenance Practices section of the Pratt and Whitney PT6A-140 Maintenance Manual P/N 3075742 found in the Introduction List of Publications.
- (23) Install the fuel motive flow hose at the motive flow shut-off valve (MFSOV). Refer to Chapter 73, Fuel Control - Maintenance Practices section of the Pratt and Whitney PT6A-140 Maintenance Manual P/N 3075742 found in the Introduction List of Publications.
- (24) Purge the fuel lines as follows:
  - (a) Push fuel firewall shutoff control fully in.
  - (b) Disconnect the supply fuel line at fuel manifold below engine.
    - 1 Cap down stream line.
    - 2 Use correct shop practices to collect fuel from open supply line.
  - (c) Use the starter to motor the engine.
  - (d) When the purge is complete, connect the fuel line to the manifold.
    - 1 Use correct shop practices to discard purged fuel.
- (25) Do an operational check of the different components on the engine.
  - (a) Start the engine and do the operational check. Refer to Pilot's Operating Handbook and FAA-Approved Airplane Flight Manual and the Pratt and Whitney PT6A-140 Maintenance Manual P/N 3075742 found in the Introduction List of Publications.
  - (b) Complete an Engine Performance Check. Refer to Chapter 71-00-05, Power Plant (PT6A-140) - Adjustment/Test, Engine Performance Check.
- (26) Shut down engine and do a check for fluid leaks, loose electrical connectors and attachment clamps and straps.
- (27) Replace engine cowling. Refer to Chapter 71, Engine Cowling and Nose Cap - Maintenance Practices.

### 3. Prepare Engine to Send for Service

- A. Before the engine is sent for service remove the components that follow.
  - (1) The engine induction air plenum. Refer to Chapter 71, Engine Cowling and Nose Cap - Maintenance Practices.
  - (2) The engine mount ring, elastomers, and engine mount brackets. Refer to Chapter 71, Engine Mount (PT6A-140) - Maintenance Practices.
  - (3) The propeller overspeed governor. For the maintenance procedures applicable to the removal and installation of the Pratt and Whitney PT6A-140 propeller overspeed governor refer to Chapter 61, Propeller Governor - Maintenance Practices section of the Pratt and Whitney PT6A-140 Maintenance Manual P/N 3075742 found in the Introduction List of Publications.
  - (4) The propeller tachometer generator. Refer to Chapter 77, Propeller RPM Indicator - Removal/Installation (PT6A-140).
  - (5) The oil temperature sensor. Refer to Chapter 79, Main Oil Temp Sensor - Maintenance Practices section of the Pratt and Whitney PT6A-140 Maintenance Manual P/N 3075742 found in the Introduction List of Publications.
  - (6) The oil cooler bracket and the oil cooler inlet, outlet tubes, tube attach bracket and clamps. Refer to Chapter 79, Oil

## Distribution - Maintenance Practices.

- (7) The standby alternator (if installed). Refer to Chapter 24, Standby Electrical System - Maintenance Practices
- (8) The torque sensing line and fittings. Refer to Chapter 77, Wet Torque Indicating System - Maintenance Practices (PT6A-140).
- (9) The engine equipment attach brackets. Refer to Chapter 71, Engine Equipment Attach Brackets - Maintenance Practices (PT6A-140).
- (10) The starter/generator cooling duct attach brackets. Refer to Chapter 80, 300 AMP Starter/Generator Cooling Air Duct - Maintenance Practices Cooling Air Duct Attach Brackets - Removal/Installation.
- (11) The engine exhaust panel. Refer to Chapter 78, Engine Primary and Secondary Exhaust Duct - Maintenance Practices (PT6A-140).

**4. Engine Build-Up**

## A. Engine Build-Up Precautions:

- (1) Take extreme care to prevent dirt, hardware, tools or other foreign material from entering engine.
- (2) Do not remove the packings and gaskets from their packages until needed for assembly purposes.
- (3) Clean the packings and gaskets, if necessary, prior to installation with dry air under pressure or with clean, lint-free rags. Do not use solvents.
- (4) Visually inspect all of the packings and gaskets for cuts, nicks, and other flaws prior to installation. In no case shall packings and gaskets that are damaged or altered be used.
- (5) Lubricate the gaskets, packings, and back-up rings with the appropriate system fluid before installation.
- (6) Handle the fuel and oil lines carefully to avoid denting or scratching them. Be especially careful not to damage the threads of fittings and line coupling nuts.
- (7) Caps should not be removed from lines until immediately before installation. If lines are disconnected for any reason, they should be recapped until ready for connection. Also, all installed lines, ducts, and electrical connectors that terminate with open ends should be capped or covered in a suitable manner to exclude the entrance of dirt and foreign objects.
- (8) Before installing a part, be sure it is thoroughly clean. Brushes used in cleaning should not mar or scratch the metal surface.
- (9) When you connect fuel and oil lines, apply anti-seize compound (JAN-A- 669) to the male threads sparingly. Be careful not to permit entry into lines.
- (10) Do not twist hose assemblies when installing. Use the stripe on the sides of the hose to find if the hose is twisted.

**NOTE:** A twisted hose under pressure can fail or loosen itself

**CAUTION:** To keep line chafing to a minimum after engine installation it is important to use correct size and type of clamps. Make sure you use the correct clamps when you attach different hoses, tubes, and wire bundles directly to the engine or to engine brackets. If clamps of insufficient size are used and tightened excessively, the line can be damaged when the engine expands because of thermal expansion. If the clamps are too tight the cables cannot slip through the clamps and chafe. Route and clamp the lines as shown.

- (11) All electrical bonding, grounding, and mating surfaces shall be clean metal surfaces free of anodic films, oxides, grease, paint, or other high-resistance film. Whenever paint has been removed to make connections, the connections shall be refinished to prevent corrosion.
- (12) Use lockwire to secure bolts and fittings as required.

## B. For the engine buildup install the components that follow.

- (1) The torque sensing line and fittings. Refer to Chapter 77, Wet Torque Indicating System - Maintenance Practices (PT6A-140).
- (2) The standby alternator (if equipped). Refer to Chapter 24, Standby Electrical System - Maintenance Practices.
- (3) The oil cooler bracket and the oil cooler inlet, outlet tubes, tube attach bracket and clamps. Refer to Chapter 79, Oil Distribution - Maintenance Practices (PT6A-140).
- (4) The engine exhaust panel. Refer to Chapter 78, Engine Primary and Secondary Exhaust Duct - Maintenance Practices (PT6A-140).

- (5) The primary exhaust stack. Refer to Chapter 78, Primary and Secondary Exhaust Duct - Maintenance Practices.
- (6) The starter/generator. Refer to Chapter 80, Starter/Generator - Maintenance Practices.
- (7) The oil temperature sensor. Refer to Chapter 79, Main Oil Temp Sensor - Maintenance Practices section of the Pratt and Whitney PT6A-140 Maintenance Manual P/N 3075742 found in the Introduction List of Publications.
- (8) The propeller tachometer generator. Refer to Chapter 77, Propeller RPM Indicator - Removal/Installation (PT6A-140).
- (9) Propeller overspeed governor. For the maintenance procedures applicable to the removal and installation of the Pratt and Whitney PT6A-140 propeller overspeed governor refer to Chapter 61, Propeller Governor - Maintenance Practice section of the Pratt and Whitney PT6A-140 Maintenance Manual P/N 3075742 found in the Introduction List of Publications.
- (10) The engine induction air plenum. Refer to Chapter 71, Engine cowling and Nose Cap - Maintenance Practices.
- (11) The engine equipment attach brackets. Refer to Chapter 71, Engine Equipment Attach Brackets - Maintenance Practices (PT6A-140).
- (12) The oil cooler attach brackets. Refer to Chapter 79 Oil Distribution - Maintenance Practices (PT6A-140), Remove/Install Oil Cooler Tube Brackets.
- (13) The starter/generator cooling duct attach brackets. Refer to Chapter 80, 300 AMP Starter/Generator Cooling Air Duct - Maintenance Practices Cooling Air Duct Attach Brackets - Removal/Installation.

Figure 201 : Sheet 1 : Engine Installation

A90730

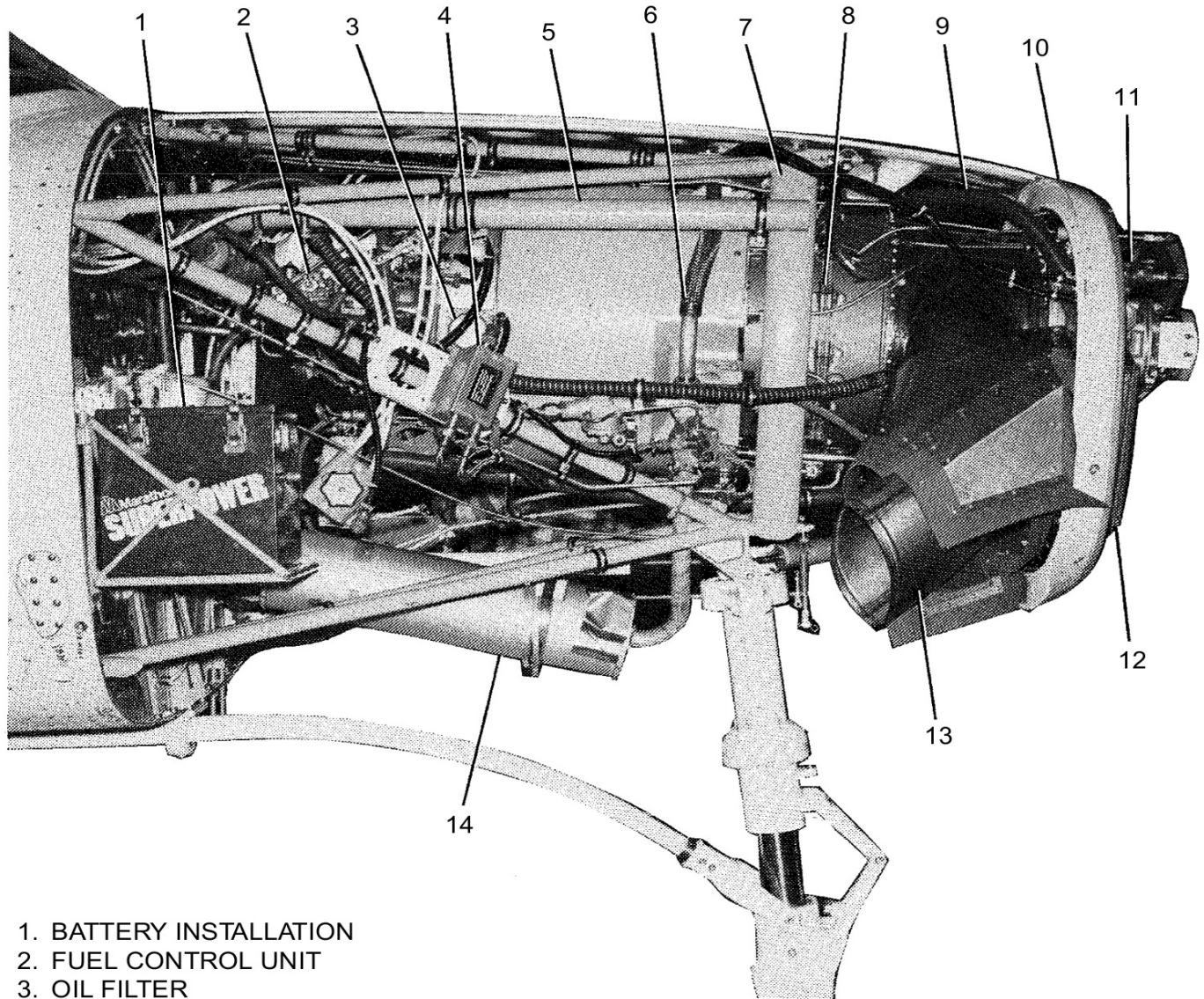

1. BATTERY INSTALLATION
2. FUEL CONTROL UNIT
3. OIL FILTER
4. IGNITION EXCITER BOX
5. STARTER/GENERATOR COOLING  
AIR BLAST TUBE
6. BLEED AIR PRESSURE LINE
7. ENGINE MOUNT RING
8. FUEL MANIFOLD
9. OIL RETURN FROM OIL COOLER
10. RIGHT COWLING BULKHEAD
11. PROPELLER GOVERNOR
12. OIL COOLER
13. PRIMARY EXHAUST STACK
14. BLEED AIR HEATER MUFFLER

2650R1002



Figure 201 : Sheet 2 : Engine Installation

A90731

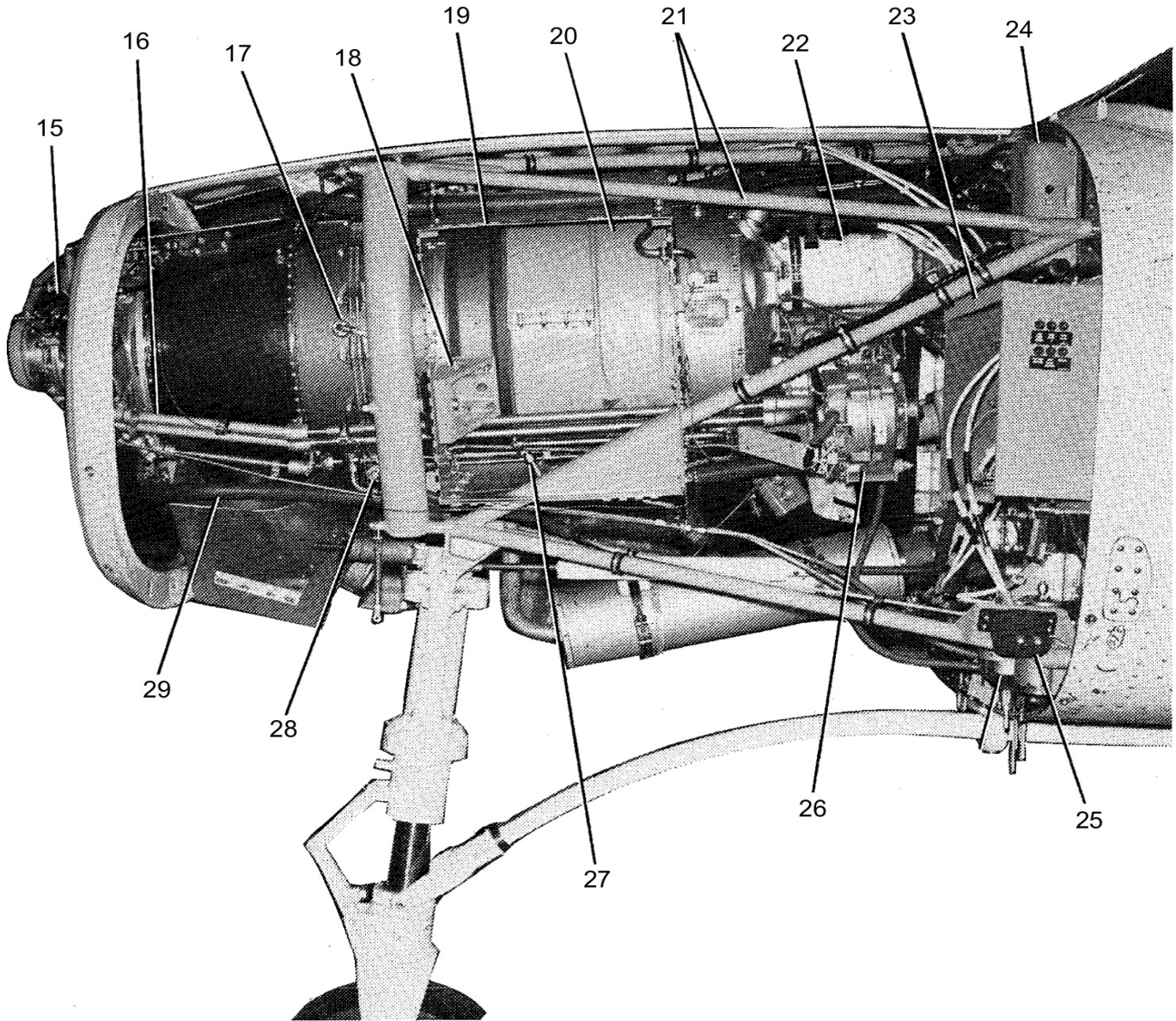

- 15. PROPELLER OVERSPEED GOVERNOR
- 16. REDUCTION GEARBOX OIL LINES
- 17. SPARK IGNITER
- 18. ENGINE MOUNT BRACKET
- 19. INDUCTION AIR PLENUM
- 20. COMPRESSOR INLET
- 21. ENGINE MOUNT TRUSS
- 22. STARTER/GENERATOR

- 23. POWER DISTRIBUTION BOX
- 24. STANDBY ALTERNATOR CONTROL UNIT
- 25. AUXILIARY POWER RECEPTACLE
- 26. STANDBY ALTERNATOR
- 27. COMPRESSOR DRAIN LINE
- 28. FUEL MANIFOLD DUMP VALVE
- 29. OIL COOLER PRESSURE HOSE

2650R1003

Figure 202 : Sheet 1 : Engine Hoisting Sling

